

**1. Product Name: LED High Bay Light
SNW-HB10C150W**



2. Specifications:

PRODUCT SPECIFICATIONS			
Product name:	150w led high bay light		
Model No.:	SNW-HB10CW150		
Power:	165W		
Working voltage:	AC90-305V, 50/60Hz		
PF:	> 0.97		
IP Grade:	IP65		
TECHNICAL CHARACTERISTICS			
Color:	Warm White	Natural White	Cool White
Color Temperature:	2700-3200K	4000-5500K	5700-6500K
CRI:	>75Ra, can be over 80Ra	>75Ra, can be over 80Ra	>75Ra, can be over 80Ra
Light Efficiency:	140lm/w		
View angle:	45° ,90° 120°		
CONFIGURATIONS			
LED chip:	203 PCS Philips 3030 SMD		
LED driver:	Mean Well HBG		
Heat sinks:	Aluminum		
Body color:	Black, Grey		
OTHERS			
Operating Temperature:	-35°C to 50°C		
Operating Humidity:	10%-90% RH		
Net Weight:	4,6KGS		
Gross Weight:	5,8KGS		
Packing size:	Ø 350 x 302mm		
Warranty:	5 Years		
Certificates:	CE, RoHS, FCC		

3. Pictures:



4. Product Size:

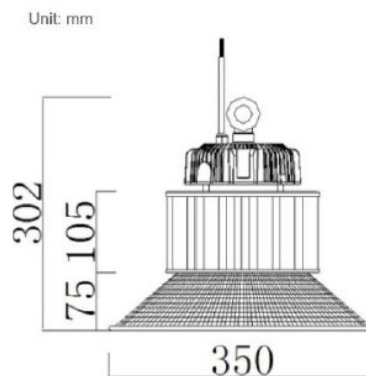

5. Advantages of this new LED high bay lights:

- 1) With Mean Well HBG driver, nice design, higher efficiency, longer life;
- 2) With Philips led chip (Nichia (Japan) is also available), and the LED are on large size PCB, the junction temperature on LED can be much lower, this guaranteed lower lumen decay and longer life of LED;
- 3) Top quality aluminum radiator with copper pipe, excellent heating dissipation;
- 4) Three different beam angle(reflector): 45° ,90° 120

Below picture is to show this LED high bay light in our display room:

